

# ARC 280-dc / ARC 400-dc

Saldatrici rotanti a corrente continua a 2 e 4 poli con spazzole. Protezione: IP 21, IP 23 su richiesta  
 Tipo di elettrodi saldabili: tutti i tipi inclusi basici e cellulosici.  
 Fornita di protezione termica contro i sovraccarichi.  
 Utilizzabile anche come alternatore  
 Forme costruttive: IM B34 - B3/B14, IM B35 B3/B9, IM B35 - J609b, SAE 3, SAE 4, SAE 5

2 and 4 poles direct-current brushes rotating welders. Protection: IP 21, on request IP 23  
 Weldable electrodes: all types, included basic and cellulosic.  
 Supplied with thermal breaker against overload.  
 Can also be used as alternator.  
 Shape: IM B34 - B3/B14, IM B35 B3/B9, IM B35 - J609b, SAE 3, SAE 4, SAE 5



VERSIONE  
 ELETTROMECCANICA  
 ELECTROMECHANICAL  
 VERSION

### Caratteristiche tecniche saldatrice / Technical characteristics welder

Tipo Type	Codice Code	Velocità Speed rpm	Massa Mass kg	Corrente di saldatura DC Welding current DC A	Tensione di innesco Strike voltage V	Tensione di saldatura Welding voltage V	Servizio Duty	Potenza assorbita Driving power
ARC 280 TDC	95004170.X2	1500	110	40÷280	70	21.6÷31.2	280 • 35 %	280A: 13.6 kW - 18.5 Hp
ARC 400 TDC	95206170.X2	3000	110	40÷400	70	21.6÷36.0	400 • 35 %	400A: 22 kW - 30 Hp
ARC 280 TDC	95004170.Q2	1800	110	40÷280	70	21.6÷31.2	280 • 35 %	280A: 13.6 kW - 18.5 Hp
ARC 400 TDC	95206170.Q2	3600	110	40÷400	70	21.6÷36.0	400 • 35 %	400A: 22 kW - 30 Hp

Tipo Type	Codice Code	Trifase (cosφ=0.8) • Three phase (cosφ=0.8)				Monofase (cosφ=1) • Single phase (cosφ=1)			
		Potenza Power (S1) - kVA	Tensione Voltage V	Corrente (max S1) Current (max S1) A	Frequenza Frequency Hz	Potenza Power (S1) - kVA	Tensione Voltage V	Corrente (max S1) Current (max S1) A	Frequenza Frequency Hz
ARC 280 TDC	95004170.X2	8	400	11.5	50	3.0	230	13,0	50
ARC 400 TDC	95206170.X2	10	400	14.4	50	4.0	230	17,4	50
ARC 280 TDC	95004170.Q2	10	416	13.9	60	4.0	240	16,6	60
ARC 400 TDC	95206170.Q2	12	416	16.6	60	5.0	240	20,8	60

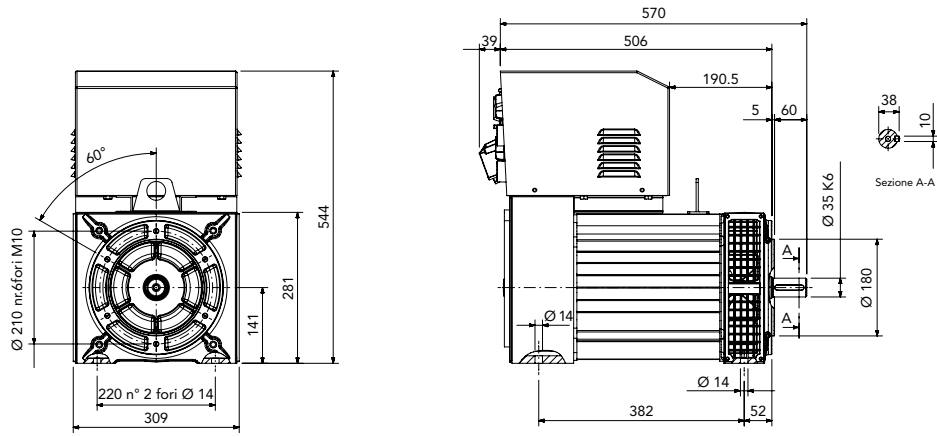

Forma costruttiva / Shape IM B34 - B3/B14 cod.E

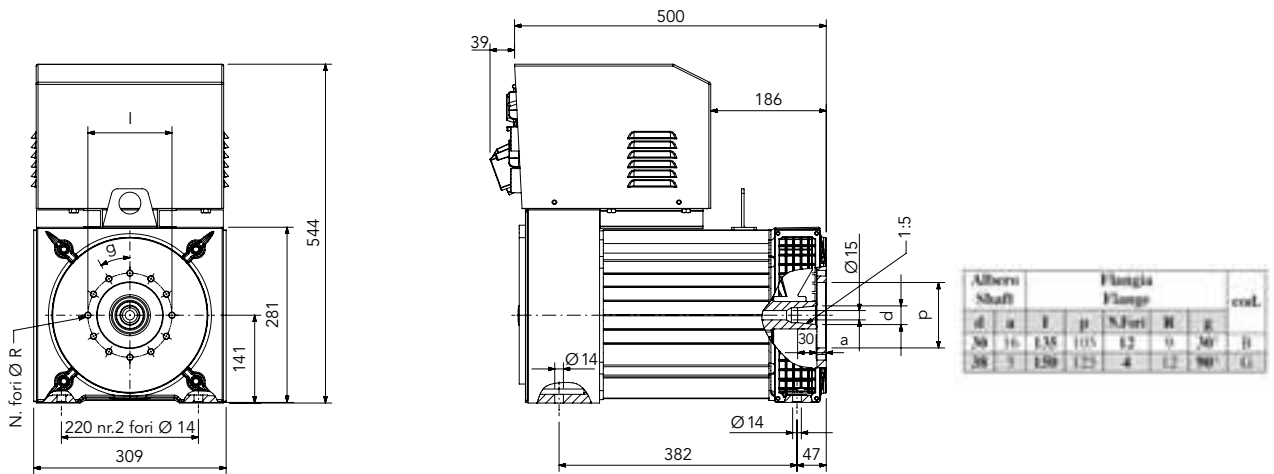

Forma costruttiva / Shape IM B35 - B3/B9 cod.B/G

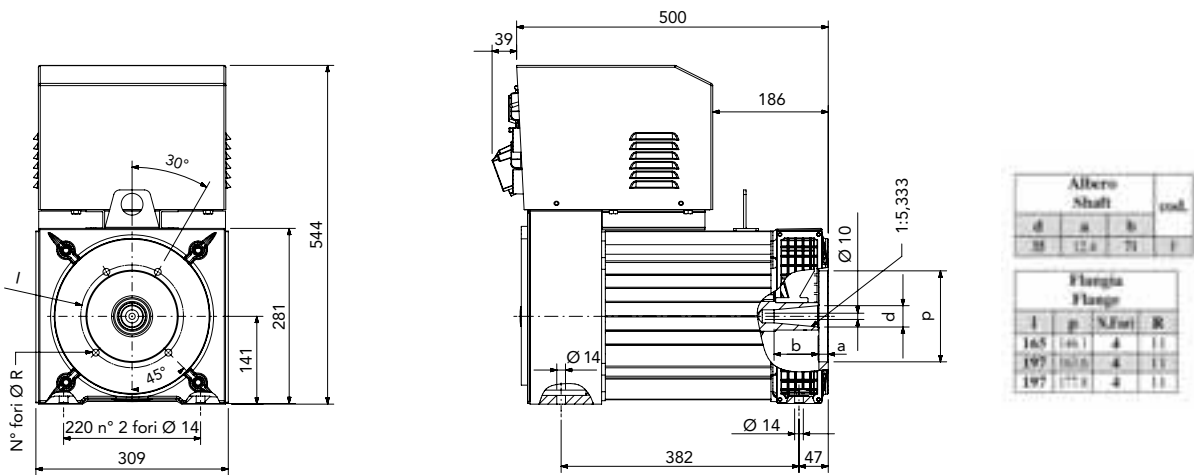

Forma costruttiva / Shape IM B35 - J609b cod. F

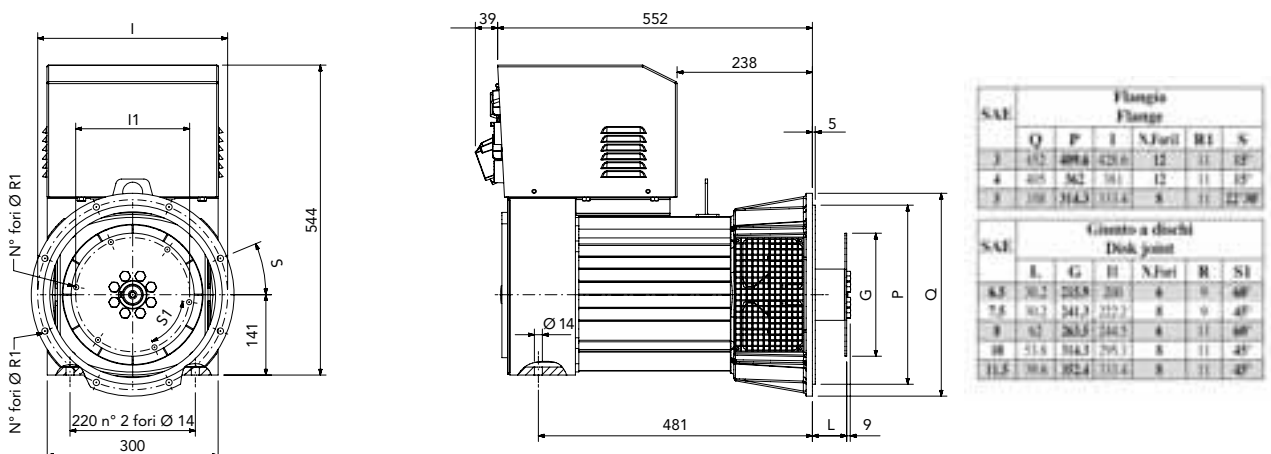

Forma costruttiva / Shape SAE cod. 3/4/5

