

EW-DC

Saldatrici rotanti a corrente continua
a 2 poli con spazzole.
Protezione: IP 21, su richiesta IP23
Tipo di elettrodi saldabili: tutti i tipi
inclusi basici e cellulosici
Fornita di protezione termica autoripristinabile
contro i sovraccarichi
Utilizzabile anche come alternatore
Forme costruttive: IM B34 - B3/B14, IM B35
B3/B9, IM B35 - J609b, SAE 5

2 poles direct-current brushes
rotating welders.
Protection: IP 21, on request IP23
Weldable electrodes: all types,
included basic and cellulosic.
Supplied with autoresettable thermal breaker
against overload
Can also be used as alternator
Shape: IM B34 - B3/B14, IM B35
B3/B9, IM B35 - J609b, SAE 5



Caratteristiche tecniche saldatrice / Technical characteristics welder

Tipo Type	Codice Code	Velocità Speed rpm	Massa Mass IMB35 kg	Corrente di saldatura DC Welding current DC A	Tensione di innesco Strike voltage V	Tensione di saldatura Welding voltage V	Servizio Duty	Potenza assorbita Driving power
EW 170 DC	96201125.A2	3000	34	45-170	80	21.8-26.6	170 A•50 %	7.5 kW • 9.5 Hp
EW 200 DC	96201180.A2	3000	43	50-200	75	22-28	200 A•35 % / 170 A•60 %	8.5 kW • 11.5 Hp
EW 220 DC	96301180.X2	3000	44	40-220	73	21.5-28.8	220 A•35 % / 170 A•60 %	9.0 kW • 12.5 Hp
EW 220 MDC	96201180.A206	3000	44	40-220	76	21.6-28.6	220 A•35 % / 170 A•60 %	9.0 kW • 12.5 Hp
EW 190 DC	96201125.F2	3600	34	50-190	82	22-27.6	190 A•50 %	8.0 kW • 11.0 Hp
EW 210 DC	96201180.F2	3600	43	50-210	82	22-28.4	210 A•35 % / 170 A•60 %	10.0 kW • 13.0 Hp
EW 240 DC	96301180.Q2	3600	44	50-240	90	22-29.6	240 A•35 % / 180 A•60 %	11.0 kW • 15.0 Hp
EW 240 MDC	96201180.F206	3600	43	50-240	90	22-29.6	240 A•35 % / 180 A•60 %	11.0 kW • 15.0 Hp

Caratteristiche tecniche alternatore / Technical characteristics alternator

Tipo Type	Codice Code	Trifase (cosφ=0.8) • Three phase (cosφ=0.8)				Monofase (cosφ=1) • Single phase (cosφ=1)			
		Potenza Power (S1) - kVA	Tensione Voltage V	Corrente (max S1) Current (max S1) A	Frequenza Frequency Hz	Potenza Power (S1) - kVA	Tensione Voltage V	Corrente (max S1) Current (max S1) A	Frequenza Frequency Hz
EW 170 DC	96201125.A2	-	-	-	-	3.0	115 / 230	26 / 13	50
EW 200 DC	96201180.A2	-	-	-	-	4.0	115 / 230	30.7 / 17.4	50
EW 220 DC	96301180.X2	6.5	400	9.4	50	3.5	231	15.2	50
EW 220 MDC	96201180.A206	-	-	-	-	5.0	115 / 230	43.5 / 21.7	50
EW 190 DC	96201125.F2	-	-	-	-	3.5	120 / 240	29.1 / 14.6	60
EW 210 DC	96201180.F2	-	-	-	-	4.0	120 / 240	33.3 / 16.7	60
EW 240 DC	96301180.Q2	7.5	416	10.4	60	3.5	240	14.6	60
EW 240 MDC	96201180.F206	-	-	-	-	5.5	120 / 240	46 / 23	60

Dimensioni / Dimensions

Tipo Type	IMB34 • IMB35 (C. 23 - C. 30)				IMB35 - J609b			
	A	B	C	D	A1	B1	C1	D1
EW 170 DC	365	69	315	283	381	85	331	283
EW 200 DC	420	124	370	338	436	140	386	338
EW 220 DC	420	124	370	338	436	140	386	338
EW 220 MDC	420	124	370	338	436	140	386	338
EW 190 DC	365	69	315	283	381	85	331	283
EW 210 DC	420	124	370	338	436	140	386	338
EW 240 DC	420	124	370	338	436	140	386	338
EW 240 MDC	420	124	370	338	436	140	386	338

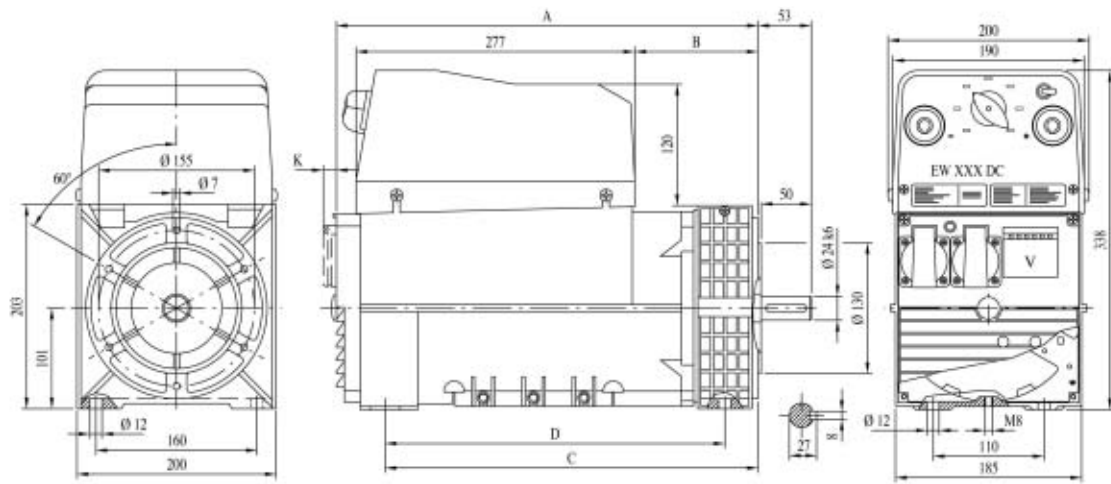

Forma costruttiva / Shape IM B34 - B3/B14 cod.E

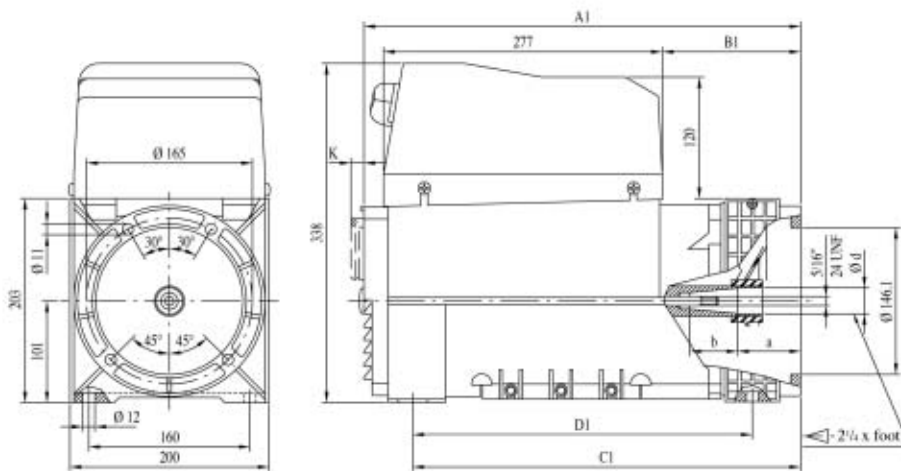

Cono/Cone	d	a	b	cod.
22,14	22,14	81	32	D
25,4	25,4	63,5	49,5	D
35	30	39	72	F

	K
Prese Schuko / Schuko sockets	16
Prese CEE / CEE sockets	47

Forma costruttiva / Shape IM B35 - J609b cod.D/F

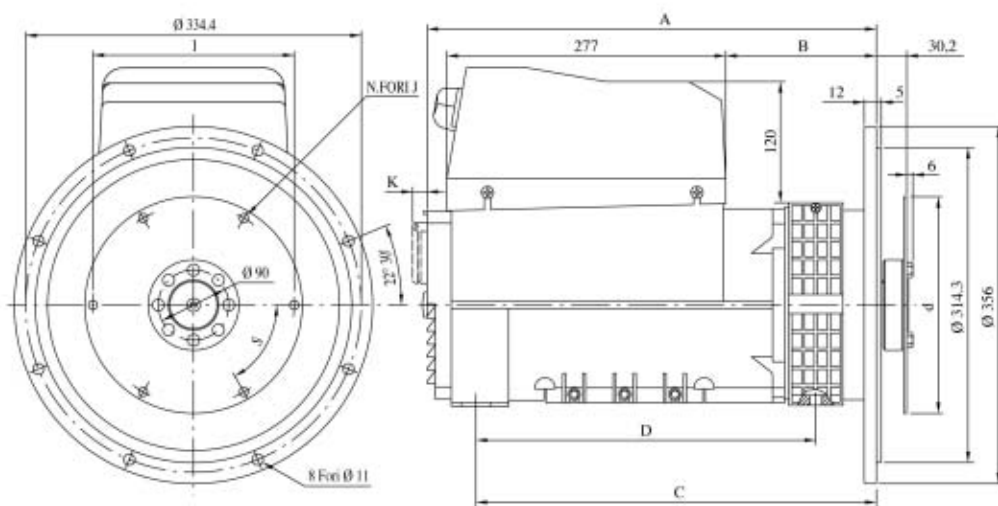

SAE	Giunto a dischi Disk joint					
	L	d	I	N.FORL	J	S
6,5	30,2	215,9	200	6	9	60°
7,5	30,2	241,3	222,1	8	9	45°

Tipo Type	Da - From IMB35 C.30			
	A'	B	C	D
EW170DC	377	81	327	283
EW190DC	377	81	327	283
EW200-220/M/DC	432	136	382	338
EW210-240/M/DC	432	136	382	338

Tipo Type	Da - From IMB35 J609b C.35			
	A'	B	C	D
EW170DC	393	97	343	283
EW190DC	393	97	343	283
EW200-220/M/DC	448	152	398	338
EW210-240/M/DC	448	152	398	338

Forma costruttiva / Shape SAE 5 cod.5

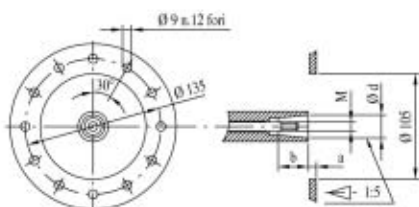

d	a	b	M	cod.
23	8	30	M8	A
30	16	30	M14	B

Forma costruttiva / Shape IM B35 - B3/B9 cod.A/B

